

Phased Arrays Improve Pipe Inspection

By David Glascock

HOUSTON—Included in the American Petroleum Institute's standards for the manufacture and performance properties of pipes and tubes used by the petroleum and natural gas industries are inspection requirements to address general conformance issues. These standards have minimal requirements for demonstrating the detection of longitudinal defects (parallel to the pipe axis), transverse defects (circumferential around the pipe diameter), and wall thickness measurements.

In addition to API standards, specific company inspection requirements may vary depending on intended use, company philosophy and associated risk. Opportunities present new challenges that often require different or more stringent performance criteria. To address these challenges, oil and gas companies may supplement standards with additional re-

quirements to address specific needs.

Supplementary specifications may include inspection for oblique defects and laminations that may become detrimental in certain environments, or the profiling of diameter and wall data to calculate more exact tubular performance relative to placement in the well.

Ultrasonic inspection systems are the preferred method of inspection for pipes with greater wall thickness and elevated performance properties. Ultrasound is sensitive to crack-like defects throughout the pipe wall thickness, and provides accurate wall thickness measurements.

Initially, these systems were configured per the API minimum inspection requirements, including longitudinal, transverse, and wall thinning inspections. Transducers were mounted in a fixture with fixed inspection angles and the pipe inspected by rotating the pipe across the fixture, or by rotating the fixture across

the pipe at a predetermined surface speed and helical advance. Electronics were analog, and reporting was done using an analogue strip chart of the inspection.

As oil and gas companies began to drill in more hostile environments, the need for higher-performance tubulars mandated that companies include inspection for defects that were off-axis to the pipe (oblique) to reduce the risk of premature failure and possible loss of life. Multiple defect orientations resulted in mechanically manipulated transducers optimized for an individual inspection direction.

Ultrasound Phased Arrays

With computerization, digital data replaced strip charts and data could be manipulated to add other evaluation tools to the inspection process, and the defective areas could be mapped relative to other specific pipe properties. The newest ad-

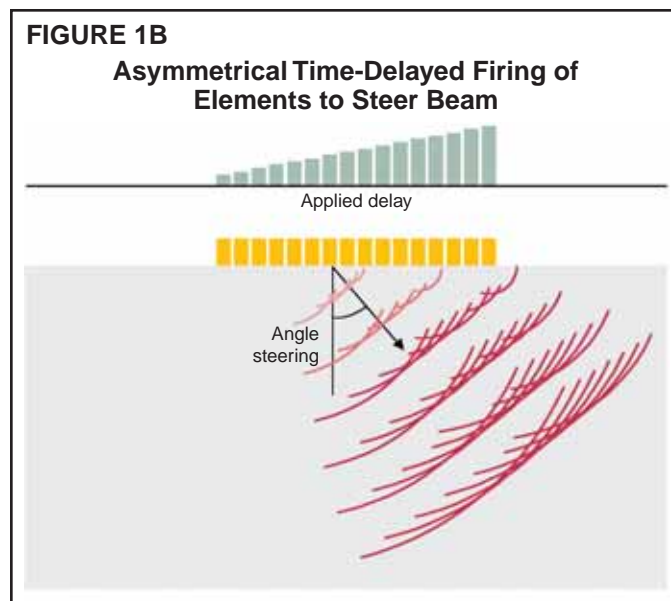
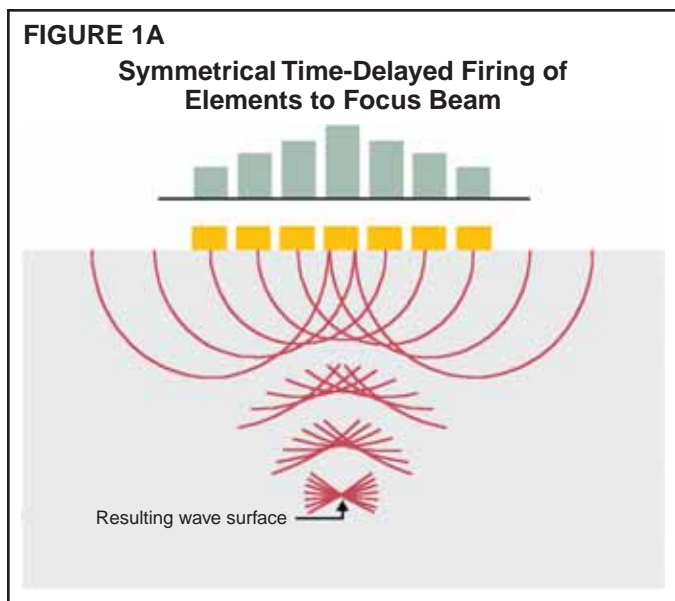
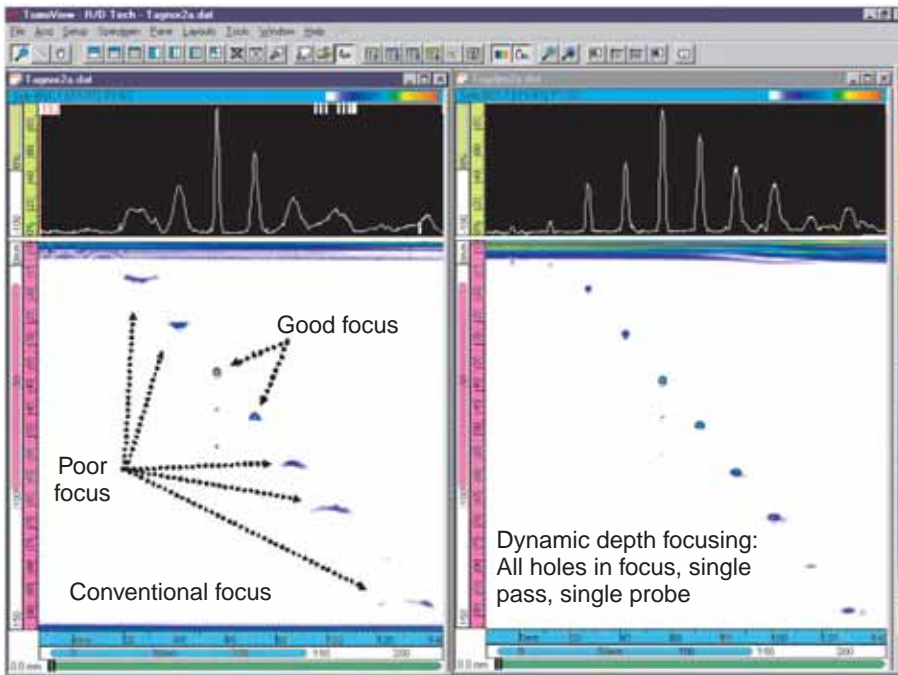



FIGURE 2
Transducer with Dynamic Depth Focusing



vancement in tubulars inspection—“virtual probe” technology using ultrasonic phased arrays—is being adapted for oil field application from technology pioneered in the medical industry

Ultrasound phased arrays provide a programmable means for electronic scanning and determining beam size angle, shape and focal distance. These arrays consist of a series of individual elements, each with its own connector, time delay circuit, and an analog-to-digital converter. Elements are acoustically insulated from one another, and are pulsed in groups with precalculated time delays for each element, i.e. “phasing.”

Electronic scanning is moving the beam along one axis of an array without any mechanical movement. This movement is performed by time multiplexing the active elements along the transducer geometry. Electronic scanning facilitates rapid scanning of components that have a constant geometry, such as tubes and pipes. Linear scanning for tubes may be implemented either laterally or circumferentially.

The electronic scanning overlap is adjustable between acoustic apertures and can be optimized to meet or exceed specified repeatability requirements. The repeatability expectations are directly related to inspection coverage density as

well as the peaks and valleys of the relative amplitude response.

Beam focusing is achieved by applying symmetrical time delays to the element firing order (e.g., parabolic) relative to the element position (Figure 1A), while dynamic depth focusing uses a series of programmable delays and apertures (focal laws) to provide for focusing at several depths using a single transducer (Figure 2). A single pulse provides examination

throughout the full depth of the wall thickness with near-optimal focus. A single transducer with dynamic depth focusing can replace many transducers with different focal lengths.

Beam steering is achieved by applying asymmetrical (e.g. linear) time delays to the element firing order (Figure 1B). Beam steering provides the flexibility for multiple angle inspections using a single transducer. Different focal laws can be used to generate both compression and shear waves with the same transducer.

The beam size and shape are determined by the element characteristics and properties, number of elements used for the beam aperture, and the applied focus parameters. Specific features are often combined to optimize inspection variables associated with different pipe inspection parameters, such as focusing and steering.

Full-Body Inspection Systems

Pipe and tube full-body phased array inspection systems typically incorporate linear, conical, flat or curved transducer arrays. These arrays are often grouped in clusters to facilitate multiple inspection directions.

A conical array cluster consists of two phased array transducers, a coupling column and a shoe with wear plate to match the diameter of the pipe. Linear scanning is used to provide inspection of the complete angular sector of the pipe covered

FIGURE 3
Oblique Defect Detection and Discrimination

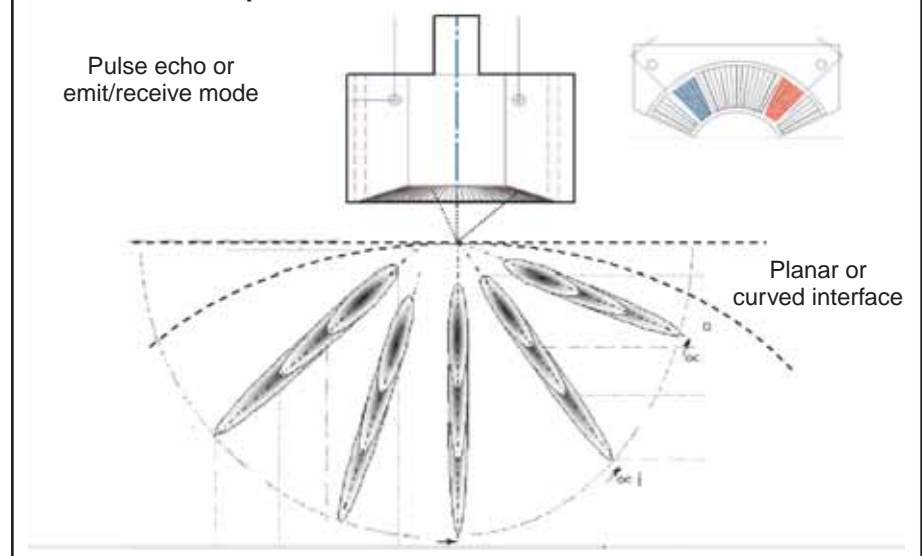



by an array transducer. Defect orientation is easily discernible by monitoring those apertures (group of elements to form the beam) with the greatest response (Figure 3).

The axial array cluster consists of two simple linear array transducers with preset incident angles in a shoe, a coupling column, and a wear plate to match the diameter of the pipe. The array transducers can be used for multiple defect orientations by generating compound angles between the fixed incident and steered programmable angles (Figure 4).

The array transducer is oriented with a predetermined fixed incident angle to generate the desired shear wave in steel. The aperture length is programmed by selecting the number of elements used to form the aperture. The array is mechanically focused parallel to the axis of the pipe to concentrate the sound energy on the surface of the pipe and reduce the scatter caused by the curved surface. One transducer is used for inspection in the clockwise direction, and a second transducer is used for inspection in the counter-clockwise direction.

The single array transducer is parallel to the axis of the pipe with no incident angle. The aperture size and incident angle is programmed by selecting the number of elements used to form the beam and the desired steering angle. The same transducer array is used for inspecting in both the leading and trailing directions by using opposing focal laws.

The array transducer is axially oriented to the pipe surface with a fixed incident angle relative to the Y-axis and a sec-

FIGURE 4

Typical Axial Array Cluster System Configuration

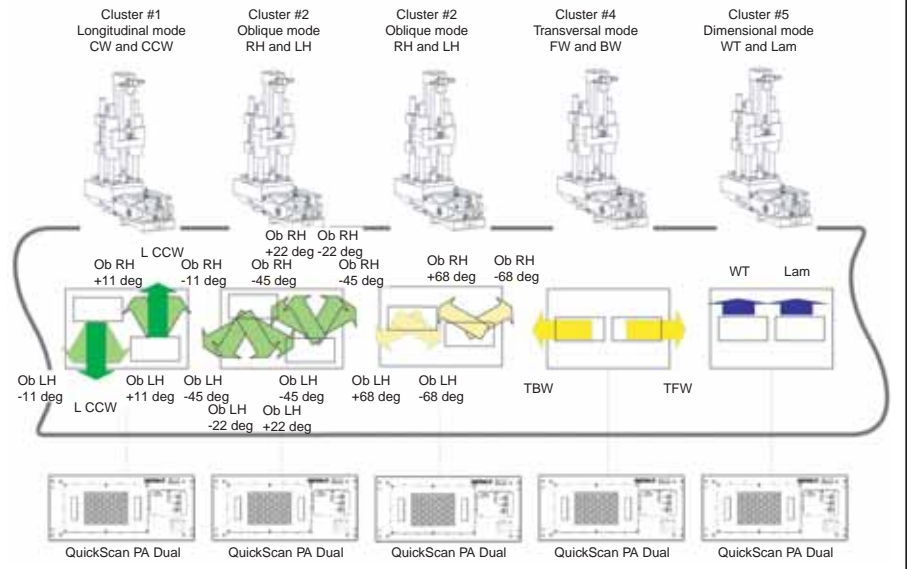

ond angle is created by electronically steering the beam along the X-axis to form a compound incident angle. The resulting refracted oblique beam is used to detect an oblique defect. The compound angles can be varied to create specific oblique angles. Additionally, in this example, the beam is manually focused along the axis of the pipe to optimize sound energy on the surface.

Electronic scanning of the beam over the weld sector is used to inspect weld lines with specified wander while maintaining calibrated response from weld flaws. Curved transducer arrays (Figure 5) are used in a weld inspection system to electronically scan across the weld area ± 30 degrees. Beam steering or sector scanning can also

be used to produce multiple inspection angles to optimize inspecting for anticipated defects.

Phased arrays provide flexibility with regard to inspection and product requirements, including programmable optimization of the beam dimensions relative to the anticipated defects, programmable adaptability of the beam coverage and inspection overlap to specified requirements, programmable optimization of the focal length and spot size for wall thickness and geometry, and programmable beam steering to maximize detection of both surface breaking and non-surface breaking defects.

The technology also enables defect analysis using multiple angle correlations, digital data and applicable algorithms with electronic scanning to minimize the need for moving mechanical parts across the weld or other areas to assure complete coverage. In addition, dynamic depth focusing can be used to evaluate multiple focal zones for heavy wall products. □

FIGURE 5

Curved Transducer for Electronic Weld Scanning

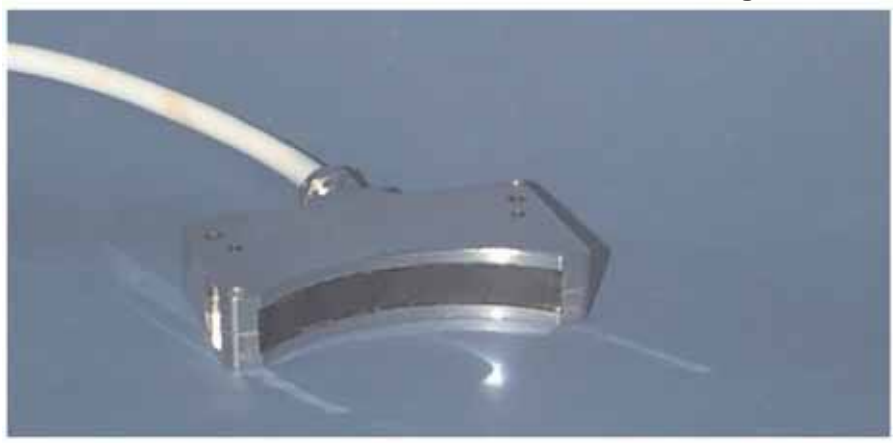

DAVID GLASCOCK is vice president of Patterson Tubular Services, Mill Systems division, in Houston, a marketing, mechanical and service partnership with RD Tech (an Olympus NDT company). He has been active in the ultrasonic inspection of OCTG products for 25 years.